

# Avonic

## CM60-IPX-BOX

Full HD 20x zoom SDI Box Camera IP White

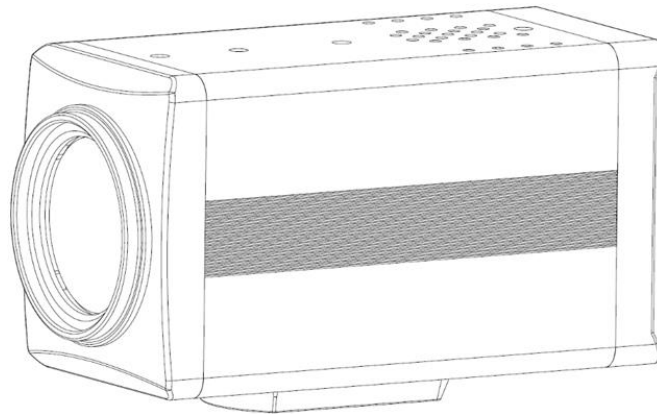

### User Manual

Version 2.0

Update notes:

Join Avonic



[linkedin.com/company/avonic](https://www.linkedin.com/company/avonic)



[twitter.com/avonic](https://twitter.com/avonic)



[facebook.com/avonic](https://facebook.com/avonic)

# Contents

<b>Introduction .....</b>	<b>6</b>
Congratulations .....	6
Safety Notes.....	6
<b>Package contents .....</b>	<b>7</b>
<b>Accessories .....</b>	<b>7</b>
<b>Product Overview .....</b>	<b>8</b>
Features .....	8
Main Unit .....	9
Input and Output Description .....	9
Bottom Parts .....	9
<b>Installation.....</b>	<b>10</b>
Connection Diagram .....	10
Power adapter .....	10
<b>Operation .....</b>	<b>11</b>
OSD Menu.....	11
MENU(Main Menu) .....	11
EXPOSURE.....	12
COLOR.....	13
IMAGE.....	14
FOCUS.....	15
NOISE REDUCTION.....	15
SETTING .....	16

INFORMATION.....	17
RESTORE FACTORY SETTINGS.....	17
Serial Communication Control.....	17
COM port settings .....	17
Command List.....	18
IP camera control.....	18
TCP/UDP Control .....	19
VLC stream media player monitoring.....	20
Homepage introduction .....	21
Media.....	22
System Setting.....	23
Network Setting.....	24
Information.....	26
<b>Maintenance.....</b>	<b>27</b>
Camera Maintenance .....	27
Unqualified Application .....	27
<b>Troubleshooting.....</b>	<b>27</b>
Image .....	27
Control .....	28
<b>Contact .....</b>	<b>28</b>
<b>Appendix A .....</b>	<b>29</b>
VISCA Camera Command List .....	29
VISCA Camera Control Command List .....	31
VISCA Query Command List.....	36
Pelco-D Protocol Command List .....	43
Pelco-P Protocol Command List.....	44

VISCA over IP commands.....	45
Camera return commands .....	45
Camera control commands .....	47
Inquiry Commands .....	53
<b>Appendix B Dimensions.....</b>	<b>57</b>

# Introduction

## Congratulations

Thank you for purchasing the Avonic CM60-IPX-BOX Integration HD Color Box Camera. Before beginning to operate this device, please read the manual in order to make sure the best performance is obtained. Save this manual for future reference.

## Safety Notes

- Installation and servicing should only be done by Qualified Service Personnel and conform to all local codes.
- This unit is designed for indoor use only and it must not be installed where exposed to water or other liquids and moisture.
- Before powering on the device, check the input power voltage carefully.
- Avoid shock and vibration when transporting and installing the device.
- Use wall mount brackets or ceiling mount brackets available at Avonic for safe installation.
- Electronic devices produce heat. Do not block the ventilation slots of the device and make sure the installation environment is well ventilated to avoid overheating.
- Before cleaning, unplug the power cable. Use a soft, damp cloth to clean the device, do not use strong or abrasive detergent to clean that will damage the device.
- If you wish to dispose this product, please contact Avonic to obtain info about the take-back procedure.

## Package contents

Quantity	Description	Avonic SKU
1 pc	PTZ Camera	CM60-IPX-BOX
1 pc	Power Supply 12V/1A	CM-PSU-BOX

## Accessories



Wall Mount for CM60-IPX-BOX

Avonic SKU : CM-WMW-BOX

# Product Overview

The Avonic CM-series cameras are designed for fixed installations. Without concessions on quality, these cameras are an affordable choice for many installations. The cameras are equipped with a Panasonic CMOS sensor combined with a glass high-quality glass lens with 12x /20x /30x optical zoom. Control these cameras over RS232/485 with the Avonic CM-CON100 PTZ controller or any third party controller that supports VISCA, Pelco-P/D protocols.

These high-quality conference video cameras, with resolutions up to 1080p/60 and h.265 encoded ultra-low bandwidth video streams, have adopted Panasonic's HD CMOS sensor, which produces high-quality images. The high SNR (55db) of the CMOS sensor combined with 2D and 3D noise reduction algorithms, effectively reduce the noise, even under low light conditions. Supports HDMI, SDI and CVBS output with high effective transmission distances. Using RS232/485 interface all the parameters of the camera can be remote-controlled.

## Features

- 20x Optical Zoom. TAMRON high quality super telephoto lens.
- H.264 and H.265 Support, enabling full HD 1080p/60fps video stream by ultra-low bandwidth, lag-time within 200ms.
- 1080P Full HD, Panasonic's 1/2.7 inch, 2.07 million effective pixels high quality HD CMOS sensor.
- Double Interface, 3G-SDI interface and IP streaming at the same time.
- Ultra-high Frame Rate up to 60fps in 1080P or even up to 120fps output in 720P over IP only.
- AAC Audio Encoding, better sound quality and smaller bandwidth.
- Low-light, high SNR of CMOS sensor combined with 2D and 3D noise reduction algorithm, effectively reduce the noise, even under low illumination conditions.
- ICR Infrared Filter with auto switch, keep watch over day and night.



# Main Unit

## Input and Output Description

1. 3G-SDI interface
2. RJ45 interface
3. Audio Line in interface
4. DC 12V power interface
5. Power light (flashing red when on)
6. Audio Line out interface
7. Right key
8. MENU key
9. Down key
10. Left key
11. Up key
12. RS485 interface

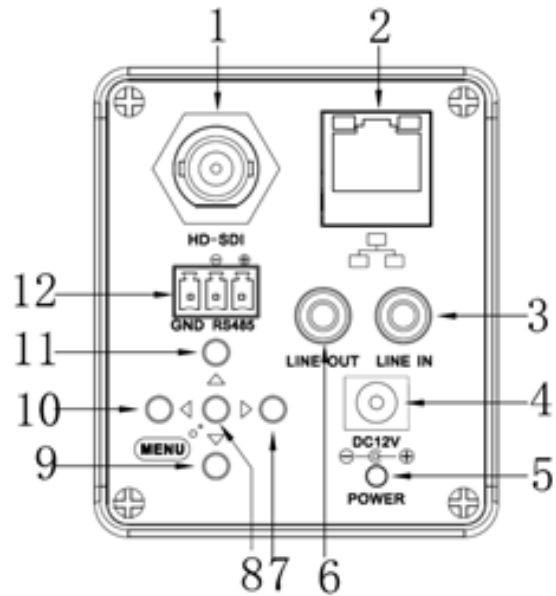

## Bottom Parts

- 1 Camera Back Cover
- 2 Installation Positioning Track
- 3 Camera Front Cover
- 4 Lens Cap

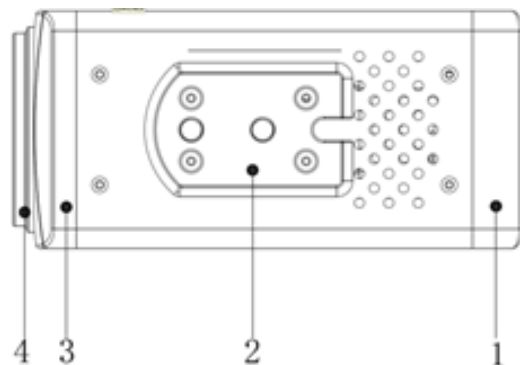

# Installation

## Connection Diagram

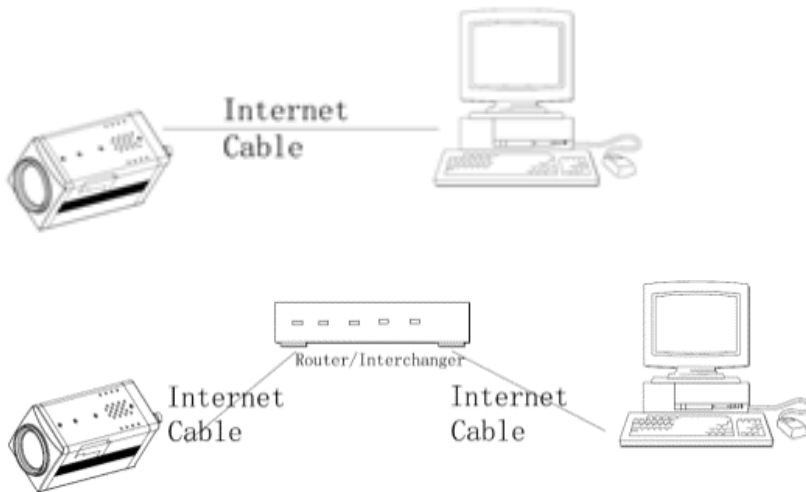

## Power adapter

This equipment is equipped with a 12V/1A DC power supply. Insert the power supply according to the requirements. The Power LED is flashing red when turned on.

# Operation

## OSD Menu

Use the 5 keys on the back of the camera to control the OSD Menu.

### MENU(Main Menu)

Directly press "MENU" button to enter the main menu.

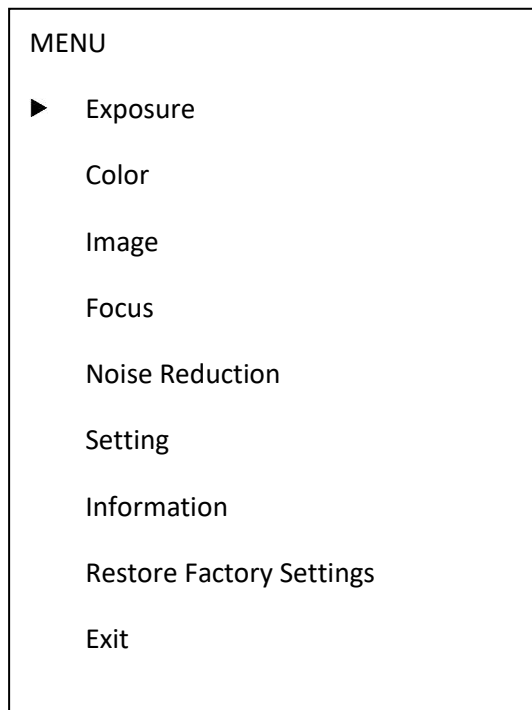

Use the select key up and down. Choose a menu item, press **【MENU】** to enter submenu.  
Choose[Exit] press **【MENU】** to exit menu.

## EXPOSURE

EXPOSURE	
▶ Mode	Auto
ExpCompMod	On
ExpComp	-1
GainLimit	3
Backlight	Off
DRC Strength	3
Anti Flicker	50Hz
Return	

- Mode: Set the camera exposure mode, Optional items: Auto, Bright, Iris Priority, Shutter Priority, Manual, WDR.
- Shutter: Set the Shutter values, only when the Mode for the Shutter Priority Mode and Manual Mode effective, Optional items: 1/10000s,1/6000s,1/4000s,1/3000s,1/2000s,1/1500s,1/1000s,1/725s,1/500s,1/350s,1/250s,1/200s,1/125s,1/100s,1/90s,1/60s,1/30s.
- Iris: Set the Iris values, only when the Mode for the Iris Priority and Manual Mode effective, Optional items:F1.8,F2.0,F2.4,F2.8,F3.4,F4.0,F4.8,F5.6,F6.8,F8.0,F9.6,F11.0,Close
- GainLimit: Set the Gain value, Optional items: 0 ~ 15.
- Bright: Set the brightness values, only when the effective Mode for Bright Mode, Optional items: 0 ~ 17.
- ExpCompMode: Set the exposure compensation mode, can be installed: On, Off.
- ExpComp: Set the exposure compensation value, only when ExpCompMode item to On effective, Optional items: -7 ~ 7.
- Backlight: Set the backlight compensation, Optional items: On, Off.
- DRC Strength: Set up digital wide dynamic strength, can set up different levels of wide dynamic effect, Optional items: 0 ~ 8.

- Anti Flicker: Set the flashing function, Optional items: 50Hz, 60Hz, Off.
- DCRStrength: Set the DRC strength values, Optional items: 0 ~ 6.
- Return: get back

## COLOR

COLOR	
▶ WB Mode	Auto
AWB Sens	Low
RG Tuning	2
BG Tuning	-1
Saturation	100%
Hue	7
Return	

- WB Mode: Set the camera white balance mode, Optional items: Auto, 3000K/Indoor, 4000K, 5000K/Outdoor, 6500K-1, 6500K-2, 6500K-3, One Push, Manual.
- RGTuning: Adjust the camera white balance mode of red tuning, are effective only when the white balance mode to Auto, Optional items: -10 ~ 10.
- BGTuning: Adjust the camera white balance mode of blue tuning, are effective only when the white balance mode to Auto, Optional items: -10 ~ 10.
- R Gain: Adjust the camera white balance mode of red gain, are effective only when the white balance mode to Manual, Optional items: 0 ~ 255.
- B Gain: Adjust the camera white balance mode of blue gain, are effective only when the white balance mode to Manual, Optional items: 0 ~ 255.
- Saturation: Color saturation adjustment, Optional items: 60% ~ 200%.
- Hue: Chroma adjustment, Optional items: 0 ~ 14.
- IR Filter: Choose IR Filter, Optional items: 1 ~ 3.

- AWB sens: The white balance sensitivity, Optional items: Low, Middle, High.
- Return: get back.

## IMAGE

IMAGE	
▶ Luminance	7
Contrast	7
Sharpness	2
Flip-H	Off
Flip-V	Off
Gamma	Default
Style	Clarity
Return	

- Luminance: Brightness adjustment, Optional items: 0~14.
- Contrast: Contrast adjustment, Optional items: 0~14.
- Sharpness: Sharpness adjustment, Optional items:Auto,0~15.
- Flip-H: Image flipped horizontally. Optional items: On, Off.
- Flip-V: Image Flip Vertical. Optional items: On, Off.
- Gamma: Optional items: default, 0.45, 0.5, 0.56, 0.63.
- Style: Optional items: Norm, Clarity, Bright, Soft,5S.
- Return: get back.

## FOCUS

FOCUS		
▶	D-Zoom Limit	x1
	AF Sensitivity	High
	Auto Focus	On

- Z-Doom Limit: Digital zoom camera settings, Optional items:x1.
- AF Sensitivity: Focus camera sensitivity, Optional items: Low, Middle, High.
- Auto Focus: Autofocus camera settings, Optional items: On, Off.
- Return: get back.

## NOISE REDUCTION

NOISE REDUCTION		
▶	2D NR	3
	3D NR	3

- 2D NR:2D noise reduction, Optional items:1 ~ 5,Close,Auto.
- 3D NR:3D noise reduction, Optional items:1 ~ 8,Close.
- Return: get back.

## SETTING

SETTING	
▶ Language	English
Protocol	VISCA
VISCA Address	1
Baudrate	9600
Video Format	1080P30
Lens	Type2
Return	

- Language: Language Settings, Optional items: English, Chinese.
- Protocol: Communication protocol Settings, Optional items: VISCA, PELCO-D, PELCO-P.
- VISCA Address: Address of the Visca Settings, Optional items: 0~7.
- P-D Address: P-D address settings, valid in PELCO-D mode, Optional items: 0~254.
- P-P Address: P-P address settings, valid in PELCO-P model, Optional items: 0~31.
- Baudrate: Camera baud rate settings, Optional items: 38400, 19200, 9600, 4800, 2400.
- Video Format: Camera video format settings, Optional items: 1080P60, 1080P50, 1080I60, 1080I50, 1080P30, 1080P25, 720P60, 720P50.
- Lens: Set lens type, Optional items: Type1, Type2.
- Return: get back.



## INFORMATION

Information	
▶ Version	7.2.01
Data	2016-08-10
AF Version	1.1.7
IP	192.168.100.99
Gateway	192.168.100.1
Netmask	255.255.255.0
Return	

## RESTORE FACTORY SETTINGS

RESTORE FACTORY SETTINGS	
▶ Yes	
No	

- Yes: verify, press **【MENU】** to restore factory Settings.
- No: cancel, press **【MENU】** to back to menu.
- Return: get back.

## Serial Communication Control

### COM port settings

RS485 Communication Control:

The camera can be controlled via RS485, Half-duplex mode:

- Baud rate: 2400/4800/9600 bit/s.
- Start bit: 1 bit.
- Data bit: 8 bits.
- Stop bit: 1bit.
- Parity bit: none.

## Command List

The camera provides the following commands to control menu over RS-485:

function	command packet	Notes
UP	8x 01 06 01 08 08 03 01 FF	Equivalent to the back four direction keys.
DOWN	8x 01 06 01 08 08 03 02 FF	
LEFT	8x 01 06 01 08 08 01 03 FF	
RIGHT	8x 01 06 01 08 08 02 03 FF	
OK	8x 01 04 0B 02 FF or 8x 01 04 0B 03 FF	Equivalent to the back <b>【MENU】</b> key.

x:Camera VISCA address number.

For the complete VISCA command list, see Appendix A

## IP camera control

IP camera default IP address is

**192.168.100.99,**

**user "admin",**

**password "admin"**

After modified, IP Camera be restarted

Unknown camera IP, view as below:

Method 1: connect camera to TV, press [menu] of the behind camera, select "Information", the camera IP will be show on screen.

Change IP address,2 methods as below:

Method 1: On web control page, find "Network"---->Change IP---->Click "Apply"

----> Restart camera

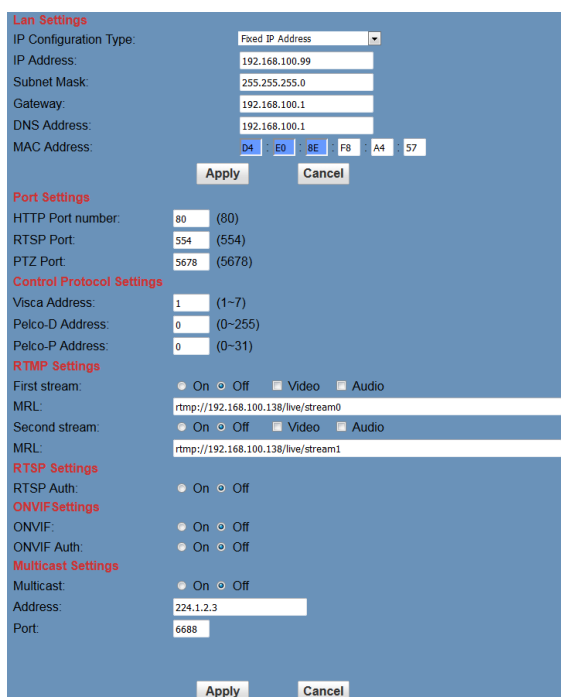

The screenshot shows the 'Lan Settings' section of the web control interface. It includes fields for IP Configuration Type (Fixed IP Address), IP Address (192.168.100.99), Subnet Mask (255.255.255.0), Gateway (192.168.100.1), DNS Address (192.168.100.1), and MAC Address (D4 E0 8E F8 A4 57). Below this are 'Port Settings' for HTTP (80), RTSP (554), and PTZ (5678). 'Control Protocol Settings' include Visca (1), Pelco-D (0), and Pelco-P (0). 'RTMP Settings' show two streams with their respective URLs. 'RTSP Settings' has an 'RTSP Auth' option. 'ONVIF Settings' has 'ONVIF' and 'ONVIF Auth' options. 'Multicast Settings' has a 'Multicast' option and an 'Address' field (224.1.2.3) and 'Port' field (6688).

## TCP/UDP Control

The Avonic IP camera is implemented with a TCP server inside. The default TCP port number is 5678. This number can be changed in the WebGUI in the Network Menu. Once the connection between client and server is set up, the client will be able to send VISCA PTZ commands to the server. The server then parses and executes the VISCA PTZ command.

The Avonic IP Camera has also implemented an UDP server inside. The UDP port number is 1259. This number cannot be changed. Once the connection between client and server is set up, the client will

be able to send VISCA PTZ commands to the server. The server then parses and executes the VISCA PTZ command.

The PTZ Command Format is according to the definition of the VISCA protocol. Not all VISCA commands are implemented for TCP/UDP control. The camera address is default set to 1. This number can be changed in the WebGUI in the Network Menu. The commands are listed in Appendix A.

## VLC stream media player monitoring

Visit VLC media server procedure

Open VLC media player, click "Media"->"Open Network Stream ",or click "Ctrl+N"; as below:

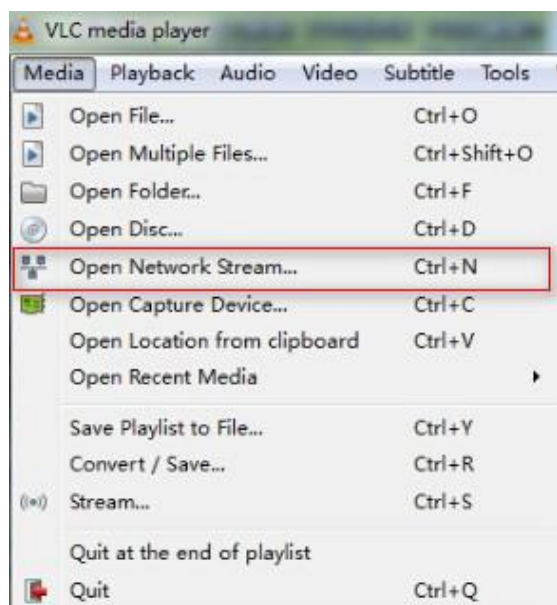

Input URL address:

rtsp://ip: port number/1 (First stream);

rtsp://ip: port number/2 (Second stream).

NOTE !

RTSP port number default value is 554.

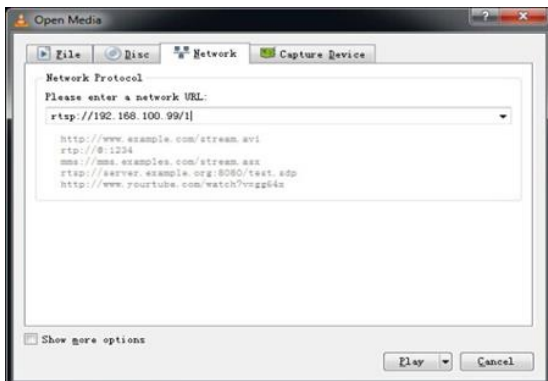

## Homepage introduction

### Menu

All pages include 2 menu bars:

1. Real time monitoring: displaying video image
2. Parameter setup: with function buttons

### Video viewing window

Video viewing window must be same as video resolution, the bigger the resolution is, the bigger the playing area is. Double click viewing window, will show full-screen, double click again, will return to initialized size.

- 1) Video playback pause button: control real-time video pause, stop the last picture, click recoverable video again.
- 2) Audio control buttons: can set silent mode.
- 3) Full screen switch button.

### Language selection

Chinese/English/Russian

## Media

**Video Settings**

Video Format:

Encode Level:

**First stream**

Encode Protocol:

Resolution:

Bit Rate:  (32~20480) kbps

Frame Rate:  fps

I Key Frame Interval:  (2~150)

Bit Rate Control:  CBR  VBR

Fluctuate Level:

**Second stream**

Encode Protocol:

Resolution:

Bit Rate:  (32~6144) kbps

Frame Rate:  fps

I Key Frame Interval:  (2~150)

Bit Rate Control:  CBR  VBR

Fluctuate Level:

1. Video format Support 50HZ and 60HZ and OSD three formats.
2. Encode Protocol  
Support H.264 and H.265 and MJPEG three formats.
3. Encode Level Support baseline, main profile, high profile.
4. Resolution  
First stream support 1920x1080,1280x720, 1024x576,960x540,640x480,640x360,Second stream support 50Hz:1280x720,1024x576,720x576, 720x408,640x360,480x270,320x240,60Hz:1280x720,1024x576,720x480,720x408,640x360,480x270,320x240,  
the bigger resolution is, the clearer the image will be, more network bandwidth will be taken.
5. Bit Rate

User can assign bit flow/stream, normally speaking, the bigger bit flow is, the clearer the image will be. The bit allocation must combine with network bandwidth, when the network bandwidth is too narrow and the allocated bit flow is too big, will cause video signal flow not to be transmitted normally, the video effect will be worse.

6. Frame rate

User can specify the size of the frame rate, generally, the frame rate greater, the image more smooth; Frame rate is smaller, the more you'll have the sense of a stuttering image.

7. I key frame interval:

Set interval between 2 I frame, the bigger interval is, the response will be lower from viewing window.

8. Bit Rate control

Code stream control way:

Constant bit rate: video coder will be coding according to preset speed

Variable bit rate: video coder will adjust the speed based on preset speed to gain the best image quality.

9. Fluctuate level

Restrain the fluctuation magnitude of variable rate, grade 1 ~ 6

## System Setting

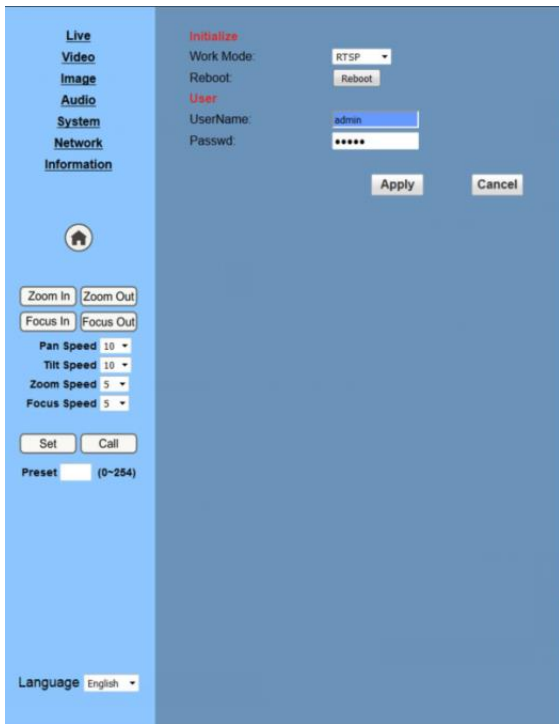

1. Work Mode  
Work Mode RTSP
2. Reboot  
Click the "Reboot" button, system restart.
3. User and password  
The user can modify the password (letters and Numbers only)
4. Apply / Cancel  
Modify password and click the "apply" button to the login page, press "cancel" button to cancel password change.

## Network Setting



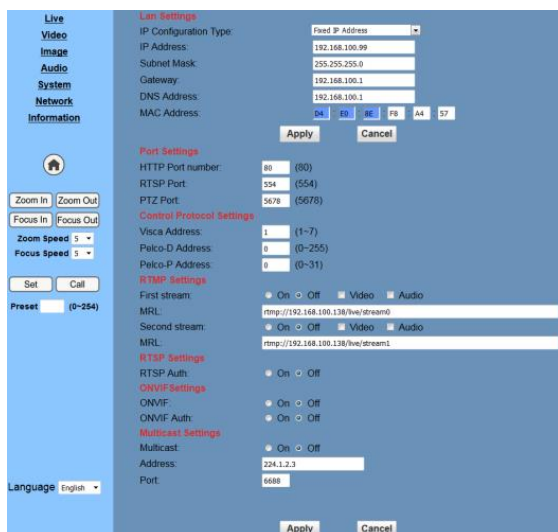

## 1. Lan Settings

Default the IP address is 192.168.100.99, The MAC address can be modified.

## 2. Port Settings

- a. HTTP Port IP address identifies the network device, the device can run multiple web applications, each network program using network port to transmit data, so data transmission to be carried out between the port and port. Port setting is to set up WEB SERVER program using which port to transmit. When port mapping, need to be consistent with the port number(default port: 80)
- b. RTSP Port Network camera support RTSP protocol, use the VLC tools broadcast.
- c. PTZ Port Support PTZ protocol, default port: 5678.

## 3. Control Protocol Setting

Setting camera control communication protocol, include Visca address, Pelco-D address, Pelco-P address.

## 4. RTMP Setting

Setting the camera stream, can set up two stream, in the two stream selection control code stream of "On", "Off", "Video", "Audio", etc.

## 5. RTSP Setting

Setting network camera RTSP protocol of "On", "Off".

## 6. ONVIF Setting

Setting the ONVIF protocol and ONVIF authorization "On", "Off".

## 7. Multicast Setting

Setting multicast "On", "Off", and multicast address(default address 224.1.2.3) and

port(default 6688)

8. Apply / Cancel

Modify network parameters then press "Apply" button to modify network parameters, press "Cancel" button to cancel network parameters.

## Information

Show the current device information, as shown to the right.

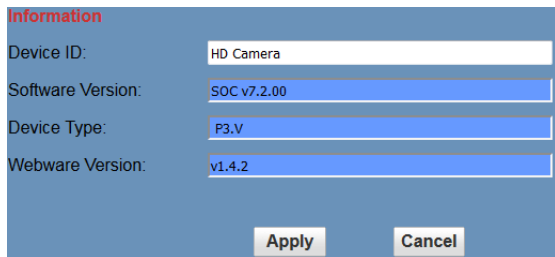

The screenshot shows a dialog box titled "Information" with a blue background. It contains four rows of information, each with a label on the left and a text input field on the right. The input fields are highlighted with a blue selection bar. At the bottom of the dialog, there are two buttons: "Apply" and "Cancel".

Label	Value
Device ID:	HD Camera
Software Version:	SOC v7.2.00
Device Type:	P3.V
Webware Version:	v1.4.2

# Maintenance

## Camera Maintenance

- If camera will not be used for a long time, disconnect AC power cord of AC adaptor to the outlet.
- Use soft cloth or tissue to clean the camera cover.
- Please use the soft dry cloth to clean the lens. If the camera is very dirty, clean it with diluted neuter detergent. Do not use any type of solvents, which may damages the surface.

## Unqualified Application

- No shooting extreme bright object for a long period of time, such as sunlight, light sources, etc.
- No operating in unstable lighting conditions, otherwise image will be flickering.
- No operating close to powerful electromagnetic radiation, such as TV or radio transmitters, etc.

# Troubleshooting

## Image

- No image
  1. Check whether the power cord is connected, voltage is OK, POWER lamp is flashing red.
  2. Check whether the camera can self-test after startup.
  3. Check the BOTTOM switch and make sure the two switches are both set OFF.
  4. Check video cable is connected correctly.
- Abnormal display of image

Check video cable is connected correctly.

- Image dithering even at widest zoom position

1. Check whether camera is fixed correctly.

2. Make sure if there are something like vibration machine or other things nearby.

## Control

- Serial communication cannot control the camera

1. Check the camera working mode.

2. Check control cable is connected correctly.

## Contact

For any questions or suggestions, contact the reseller or the local distributor of Avonic. Find the local distributor on the website of Avonic.

For the recent manual or datasheet, look at the Avonic website.

[www.avonic.eu](http://www.avonic.eu)

# Appendix A

## VISCA Camera Command List

x= Camera Address

y= Socket Number

z = Camera Address + 8

Command	Function	Command Package	Note
<b>AddressSet</b>	Broadcast	88 30 01 FF	Address setting
<b>IF_Clear</b>	Broadcast	88 01 00 01 FF	I/F Clear
<b>CAM_Power</b>	On	8x 01 04 00 02 FF	Power ON/OFF
	Off	8x 01 04 00 03 FF	
<b>CAM_Zoom</b>	Stop	8x 01 04 07 00 FF	
	Tele(Standard)	8x 01 04 07 02 FF	
	Wide(Standard)	8x 01 04 07 03 FF	
	Tele(Variable)	8x 01 04 07 2p FF	p = 0(low) - 7(high)
	Wide(Variable)	8x 01 04 07 3p FF	
	Direct	8x 01 04 47 0p 0q 0r 0s FF	pqrs: Zoom Position

Command	Function	Command Package	Note
<b>ACK/Completion Messages</b>	ACK	z0 4y FF (y: Socket No.)	Return when the command is accepted.

Completion	z0 5y FF (y: Socket No.)	Return when the command has been executed.
------------	-----------------------------	--

Command	Function	Command Package	Note
<b>Error Messages</b>	Syntax Error	z0 60 02 FF	Returned when the command format is different or when a command with illegal command parameters is accepted.
	Command Buffer Full	z0 60 03 FF	Indicates that two sockets are already being used(executing two commands) and the command could not be accepted when received.
	Command Canceled	z0 6y 04 FF (y: Socket No.)	Returned when a command which is being executed in a socket specified by the cancel command is canceled. The completion message for the command is not returned.
	No Socket	z0 6y 05 FF (y: Socket No.)	Returned when no command is executed in a socket specifild by the cancel command, or when an invalid socket number is specified.
	Command Not Executable	z0 6y 41 FF (y: Execution command Socket No. Inquiry command: 0)	Returned when a command cannot be executed due to current conditions.For example, when commands controlling the focus manually are received during auto focus.

## VISCA Camera Control Command List

Command	Function	Command Package	Notes
<b>CAM_Focus</b>	Stop	8x 01 04 08 00 FF	
	Far(Standard)	8x 01 04 08 02 FF	
	Near(Standard)	8x 01 04 08 03 FF	
	Far(Variable)	8x 01 04 08 2p FF	p = 0(low) - 7(high)
	Near(Variable)	8x 01 04 08 3p FF	
	Direct	8x 01 04 48 0p 0q 0r 0s FF	pqrs: Focus Position
	Auto Focus	8x 01 04 38 02 FF	AF On
	Manual Focus	8x 01 04 38 03 FF	AF Off
	Auto/Manual	8x 01 04 38 10 FF	AF Toggle On/Off
<b>CAM_ZoomFocus</b>	Direct	8x 01 04 47 0p 0q 0r 0s	pqrs: Zoom Position
		0t 0u 0v 0w FF	p=0-4 qrs=0-F tuvw: Focus Position
<b>CAM_WB</b>	Auto	8x 01 04 35 00 FF	Normal Auto
	Indoor mode	8x 01 04 35 01 FF	Indoor mode
	Outdoor mode	8x 01 04 35 02 FF	Outdoor mode
	OnePush mode	8x 01 04 35 03 FF	One Push WB mode
	Manual	8x 01 04 35 05 FF	Manual Control mode
	OnePush trigger	8x 01 04 10 05 FF	One Push WB Trigger
<b>CAM_RGain</b>	Reset	8x 01 04 03 00 FF	Manual Control of R Gain
	Up	8x 01 04 03 02 FF	
	Down	8x 01 04 03 03 FF	

	Direct	8x 01 04 43 00 00 0p 0q FF	pq: R Gain
<b>CAM_Bgain</b>	Reset	8x 01 04 04 00 FF	Manual Control of B Gain
	Up	8x 01 04 04 02 FF	
	Down	8x 01 04 04 03 FF	
	Direct	8x 01 04 44 00 00 0p 0q FF	pq: B Gain
<b>CAM_AE</b>	Full Auto	8x 01 04 39 00 FF	Automatic Exposure mode
	Manual	8x 01 04 39 03 FF	Manual Control mode
	Shutter priority	8x 01 04 39 0A FF	Shutter Priority Automatic Exposure mode
	Iris priority	8x 01 04 39 0B FF	Iris Priority Automatic Exposure mode
	Bright	8x 01 04 39 0D FF	Bright Mode(Manual control)
<b>CAM_SlowShutter</b>	AutoSlowShutterLimit	8x 01 04 2A 0p 00 FF	
<b>CAM_Iris</b>	Reset	8x 01 04 0B 00 FF	Iris Setting
	Up	8x 01 04 0B 02 FF	
	Down	8x 01 04 0B 03 FF	
	Direct	8x 01 04 4B 00 00 0p 0q FF	pq: Iris Position
<b>CAM_Gain</b>	Reset	8x 01 04 0C 00 FF	Gain Setting
	Up	8x 01 04 0C 02 FF	
	Down	8x 01 04 0C 03 FF	
	Direct	8x 01 04 0C 00 00 0p 0q FF	pq: Gain Position
	Gain Limit	8x 01 04 2C 0p FF	p: Gain Position



<b>CAM_Bright</b>	Reset	8x 01 04 0D 00 FF	Bright Setting
	Up	8x 01 04 0D 02 FF	
	Down	8x 01 04 0D 03 FF	
	Direct	8x 01 04 0D 00 00 0p 0q FF	pq: Bright Position
<b>CAM_ExpComp</b>	On	8x 01 04 3E 02 FF	Exposure
	Off	8x 01 04 3E 03 FF	Compensation On/Off
	Reset	8x 01 04 0E 00 FF	Exposure
	Up	8x 01 04 0E 02 FF	Compensation Amount
	Down	8x 01 04 0E 03 FF	Setting
	Direct	8x 01 04 4E 00 00 0p 0q FF	pq: ExpComp Position
<b>CAM_BackLight</b>	On	8x 01 04 33 02 FF	Back Light
	Off	8x 01 04 33 03 FF	Compensation On/Off
<b>CAM_NR(2D)Mode</b>	Auto	8x 01 04 50 02 FF	ND2D Auto/Manual
	Manual	8x 01 04 50 03 FF	
<b>CAM_NR(2D)Level</b>	-	8x 01 04 53 0p FF	p: NR Setting (0: Off, level 1 to 5)
<b>CAM_NR(3D)Level</b>	-	8x 01 04 54 0p FF	p: NR Setting (0: Off, level 1 to 8)
<b>CAM_Flicker</b>	-	8x 01 04 23 0p FF	p: Flicker Settings
			(0: Off, 1: 50Hz, 2: 60Hz)
<b>CAM_DHotPixel</b>	-	8x 01 04 56 0p FF	p: Dynamic Hot Pixel Setting (0: Off, level 1 to 6)
<b>CAM_ApertureMode (sharpness)</b>	Auto	8x 01 04 05 02 FF	Sharpness Auto
	Manual	8x 01 04 05 02 FF	Sharpness Manual
	Reset	8x 01 04 02 00 FF	Aperture Control

<b>CAM_Aperture (sharpness)</b>	Up	8x 01 04 02 02 FF	
	Down	8x 01 04 02 03 FF	
	Direct	8x 01 04 42 00 00 0p 0q FF	pq: Aperture Gain
<b>CAM_PictureEffect</b>	Off	8x 01 04 63 00 FF	Picture Effect Setting
	B&W	8x 01 04 63 04 FF	
<b>CAM_Memory</b>	Reset	8x 01 04 3F 00 pp FF	pp: Memory Number(=0 to 127)
	Set	8x 01 04 3F 01 pp FF	
	Recall	8x 01 04 3F 02 pp FF	
<b>CAM_LR_Reverse</b>	On	8x 01 04 61 02 FF	Image Flip Horizontal On/Off
	Off	8x 01 04 61 03 FF	
<b>CAM_PictureFlip</b>	On	8x 01 04 66 02 FF	Image Flip Vertical On/Off
	Off	8x 01 04 66 03 FF	
<b>CAM_RegisterValue</b>	-	8x 01 04 24 mn 0p 0q FF	mm: Register No. (=00-7F) pp: Register Value (=00-7F)
<b>CAM_ColorGain</b>	Diret	8x 01 04 49 00 00 00 0p FF	p: Color Gain setting 0h (60%) to Eh
			-200%
<b>SYS_Menu</b>	Off	8x 01 06 06 03 FF	Turns off the menu screen
<b>Pan_tiltDrive</b>	Up	8x 01 06 01 VV WW 03 01 FF	VV: Pan speed 0x01 (low speed) to 0x18
		8x 01 06 01 VV WW 03 02 FF	(high speed)
	Left	8x 01 06 01 VV WW 01 03 FF	WW: Tilt speed 0x01 (low speed) to 0x14
		8x 01 06 01 VV WW 02 03 FF	(high speed)

	Upleft	8x 01 06 01 VV WW 01 01 FF	YYYY: Pan Position
	Upright	8x 01 06 01 VV WW 02 01 FF	ZZZZ: Tilt Position
	DownLeft	8x 01 06 01 VV WW 01 02 FF	
	DownRight	8x 01 06 01 VV WW 02 02 FF	
	Stop	8x 01 06 01 VV WW 03 03 FF	
	AbsolutePosition	8x 01 06 02 VV WW 0Y 0Y 0Y 0Y 0Z 0Z 0Z 0Z FF	
	RelativePosition	8x 01 06 03 VV WW v0Y 0Y 0Y 0Y 0Z 0Z 0Z 0Z FF	
	Home	8x 01 06 04 FF	
	Reset	8x 01 06 05 FF	
<b>Pan_tiltLimitSet</b>	LimitSet	8x 01 06 07 00 0W 0Y 0Y 0Y 0Y 0Z 0Z 0Z 0Z FF	W: 1 UpRight 0: DownLeft YYYY: Pan Limit Position
	LimitClear	8x 01 06 07 01 0W 07 0F 0F 0F 07 0F 0F 0F FF	ZZZZ: Tilt Position
<b>CAM_AFSensitivity</b>	High	8x 01 04 58 01 FF	AF Sensitivity High/Normal/Low
	Normal	8x 01 04 58 02 FF	
	Low	8x 01 04 58 03 FF	
<b>CAM_SettingReset</b>	Reset	8x 01 04 A0 10 FF	Reset Factory Setting
<b>CAM_Brightness</b>	Direct	8x 01 04 A1 00 00 0p 0q FF	pq: Brightness Position

<b>CAM_Contrast</b>	Direct	8x 01 04 A2 00 00 0p 0q FF	pq: Contrast Position
<b>CAM_Flip</b>	Off	8x 01 04 A4 00 FF	
	Flip-H	8x 01 04 A4 01 FF	
	Flip-V	8x 01 04 A4 02 FF	
	Flip-HV	8x 01 04 A4 03 FF	Single Command For Video Flip
<b>CAM_SettingSave</b>	Save	8x 01 04 A5 10 FF	Save Current Setting
<b>CAM_Iridix</b>	Direct	8x 01 04 A7 00 00 0p 0q FF	pq: Iridix Position
<b>CAM_AWBSensitivity</b>	High	8x 01 04 A9 00 FF	High
	Normal	8x 01 04 A9 01 FF	Normal
	Low	8x 01 04 A9 02 FF	Low
<b>CAM_AFZone</b>	Top	8x 01 04 AA 00 FF	AF Zone weight select
	Center	8x 01 04 AA 01 FF	
	Bottom	8x 01 04 AA 02 FF	
<b>CAM_ColorHue</b>	Direct	8x 01 04 4F 00 00 00 0p FF	p: Color Hue setting 0h (- 14 dgree) to Eh ( +14 degrees

## VISCA Query Command List

Command	Command Package	Return Package	Note
<b>CAM_PowerInq</b>	8x 09 04 00 FF	y0 50 02 FF	On
		y0 50 03 FF	Off(Standby)
		y0 50 04 FF	Internal power circuit error
<b>CAM_ZoomPosInq</b>	8x 09 04 47 FF	y0 50 0p 0q 0r 0s FF	pqrs: Zoom Position

<b>CAM_FocusAFMode</b>	8x 09 04 38 FF	y0 50 02 FF	Auto Focus
<b>Inq</b>		y0 50 03 FF	Manual Focus
<b>CAM_FocusPosInq</b>	8x 09 04 48 FF	y0 50 0p 0q 0r 0s FF	pqrs: Focus Position
<b>CAM_WBModelInq</b>	8x 09 04 35 FF	y0 50 00 FF	Auto
		y0 50 01 FF	Indoor mode
		y0 50 02 FF	Outdoor mode
		y0 50 03 FF	OnePush mode
		y0 50 05 FF	Manual
<b>CAM_RGainInq</b>	8x 09 04 43 FF	y0 50 00 00 0p 0q FF	pq: R Gain
<b>CAM_BGainInq</b>	8x 09 04 44 FF	y0 50 00 00 0p 0q FF	pq: B Gain
<b>CAM_AEModeInq</b>	8x 09 04 39 FF	y0 50 00 FF	Full Auto
		y0 50 03 FF	Manual
		y0 50 0A FF	Shutter priority
		y0 50 0B FF	Iris priority
		y0 50 0D FF	Bright
<b>CAM_ShutterPosInq</b>	8x 09 04 4A FF	y0 50 00 00 0p 0q FF	pq: Shutter Position
<b>CAM_IrisPosInq</b>	8x 09 04 4B FF	y0 50 00 00 0p 0q FF	pq: Iris Position
<b>CAM_BrightPosInq</b>	8x 09 04 4D FF	y0 50 00 00 0p 0q FF	pq: Bright Position
<b>CAM_ExpCompMod</b>	8x 09 04 3E FF	y0 50 02 FF	On
		y0 50 03 FF	Off
<b>eInq</b>			
<b>CAM_ExpCompPosInq</b>	8x 09 04 4E FF	y0 50 00 00 0p 0q FF	pq: ExpComp Position
<b>CAM_BacklightMode</b>	8x 09 04 33 FF	y0 50 02 FF	On
		y0 50 03 FF	Off
<b>Inq</b>			
<b>CAM_Nosise2DMode</b>	8x 09 04 50 FF	y0 50 02 FF	Auto Noise 2D
		y0 50 03 FF	Manual Noise 3D
<b>Inq</b>			

<b>CAM_Noise2DLevel</b>	8x 09 04 53 FF	y0 50 0p FF	Noise Reduction (2D) p: 0 to 5
<b>CAM_Noise3DLevel</b>	8x 09 04 54 FF	y0 50 0p FF	Noise Reduction (3D) p: 0 to 8
<b>CAM_FlickerModelnq</b>	8x 09 04 55 FF	y0 50 0p FF	p: Flicker Settings(0: OFF, 1: 50Hz, 2: 60Hz)
<b>CAM_ApertureModelnq(Sharpness)</b>	8x 09 04 05 FF	y0 50 02 FF	Auto Sharpness
		y0 50 03 FF	Manual Sharpness
<b>CAM_ApertureInq(Sharpness)</b>	8x 09 04 42 FF	y0 50 00 00 0p 0q FF	pq: Aperture Gain
<b>CAM_PictureEffectModelnq</b>	8x 09 04 63 FF	y0 50 02 FF	Off
		y0 50 04 FF	B&W
<b>CAM_MemoryInq</b>	8x 09 04 3F FF	y0 50 0p FF	p: Memory number last operated.
<b>SYS_MenuModelnq</b>	8x 09 06 06 FF	y0 50 02 FF	On
		y0 50 03 FF	Off
<b>CAM_LR_ReverseInq</b>	8x 09 04 61 FF	y0 50 02 FF	On
		y0 50 03 FF	Off
<b>CAM_PictureFlipInq</b>	8x 09 04 66 FF	y0 50 02 FF	On
		y0 50 03 FF	Off
<b>CAM_RegisterValueInq</b>	8x 09 04 24 mm FF	y0 50 0p 0p ff	mm: Register No. (00 to FF) pp: Register Value (00 to FF)
<b>CAM_ColorGainInq</b>	8x 09 04 49 FF	y0 50 00 00 00 0p FF	p: Color Gain setting 0h (60%) to Eh (200%)
<b>CAM_IDInq</b>	8x 09 04 22 FF	y0 50 0p 0q 0r 0s FF	pqrs: Camera ID

<b>CAM_VersionInq</b>	8x 09 00 02 FF	y0 50 ab cd mn pq rs tu vw FF	ab: Factory Code cd: Hardware Version mnpq: ARM Version rstu: FPGA Version vw: Camera model 01: C Type 02: M Type 03: S Type
<b>VideoSystemInq</b>	8x 09 06 23 FF	y0 50 00 FF	1920x1080i60
		y0 50 01 FF	1920x1080p30
		y0 50 02 FF	1280x720p60
		y0 50 04 FF	NTSC
		y0 50 05 FF	NTSC
		y0 50 06 FF	NTSC
		y0 50 07 FF	1920x1080p60
		y0 50 08 FF	1920x1080i50
		y0 50 09 FF	1920x1080p25
		y0 50 0A FF	1280x720p50
		y0 50 0C FF	PAL
		y0 50 0D FF	PAL
		y0 50 0E FF	PAL
<b>IR_Receive</b>	8x 09 06 08 FF	y0 50 02 FF	On
		y0 50 03 FF	Off
<b>Pan-tiltMaxSpeedInq</b>	8x 09 06 11 FF	y0 50 ww zz FF	ww: Pan Max Speed zz: Tilt Max Speed
<b>Pan-tiltPosInq</b>	8x 09 06 12 FF	y0 50 0w 0w 0w 0w	www: Pan Position
		0z 0z 0z 0z FF	zzzz: Tilt Position

<b>CAM_TypeInq</b>	8x 09 00 03 FF	y0 50 01 FF	C Type
		y0 50 02 FF	M Type
		y0 50 03 FF	S Type
<b>CAM_DateInq</b>	8x 09 00 04 FF	y0 50 0r ss uu vv ww 0D FF	Version dater: Big Version Numberss:  Little Version Numberuuuu: Yearvv:  Monthww: Day
<b>CAM_ModelInq</b>	8x 09 04 A6 FF	y0 50 00 FF	Mode0
		y0 50 02 FF	Mode2
<b>CAM_GainLimitInq</b>	8x 09 04 2C FF	y0 50 0q FF	p: Gain Limit
<b>CAM_DHotPixelInq</b>	8x 09 04 56 FF	y0 50 0q FF	p: Dynamic Hot Pixel Setting (0: Off, level 1 to 6)
<b>CAM_AFSensitivityInq</b>	8x 09 04 58 FF	y0 50 01 FF	High
		y0 50 02 FF	Normal
		y0 50 03 FF	Low
<b>CAM_BrightnessInq</b>	8x 09 04 A1 FF	y0 50 00 00 0p 0q FF	pq: Brightness Position
<b>CAM_ContrastInq</b>	8x 09 04 A2 FF	y0 50 00 00 0p 0q FF	pq: Contrast Position
<b>CAM_FlipInq</b>	8x 09 04 A4 FF	y0 50 00 FF	Off
		y0 50 01 FF	Flip-H
		y0 50 02 FF	Flip-V
		y0 50 03 FF	Flip-HV
<b>CAM_IridixInq</b>	8x 09 04 A7 FF	y0 50 00 00 0p 0q FF	pq: Iridix Position
<b>CAM_AFZone</b>	8x 09 04 AA FF	y0 50 00 FF	Top
		y0 50 01 FF	Center
		y0 50 02 FF	Bottom



<b>CAM_ColorHueInq</b>	8x 09 04 4F FF	y0 50 00 00 00 0p FF	p: Color Hue setting 0h (- 14 dgree) to Eh ( +14 degrees
<b>CAM_AWBSensitivit yInq</b>	8x 09 04 A9 FF	y0 50 00 FF	High
		y0 50 01 FF	Normal
		y0 50 02 FF	Low

Command	Command Package	Return Package	Note
<b>CAM_LensBlockInq</b>	8x 09 7E 7E 00 FF	y0 50 0u 0u 0u 0u 00 00 0v 0v 0v 0v 00 0w 00 FF	uuuu: Zoom Position vvvv: Focus Position w.bit0: Focus Mode 1: Auto 0: Manual
<b>CAM_CameraBlockInq</b>	8x 09 7E 7E 01 FF	y0 50 0p 0p 0q 0q 0r 0s tt 0u vv ww 00 xx 0z FF	pp: R_Gain qq: B_Gain r: WB Mode s: Aperture tt: AE Mode uu: BackLight uu Exp Comp. vv: Shutter Position ww: Iris Position xx Bright Position z: Exp Comp. Position
<b>CAM_OtherBlockInq</b>	8x 09 7E 7E 02 FF	y0 50 0p 0q 00 0r 00 00 00 00 00 00 00 00 00 FF	p.bit0: Power 1:On, 0:Off q.bit2: LR Reverse 1:On, 0:Off r.bit3~0: Picture Effect Mode

<b>CAM_EnlargementBlockInq</b>	8x 09 7E 7E 03 FF	y0 50 00 00 00 00 00 00 00 0p 0q rr 0s 0t 0u FF	p: AF sensitivity q: bit0: Picture flip(1:On, 0:Off) rr.bit6~3: Color Gain (0h(60%) to Eh(200%)) s: Flip(0: Off, 1:Flip-H, 2:Flip-V, 3:Flip-HV) t: bit2~0: NR2D level u: Gain limit
--------------------------------	-------------------	---	--

Remark :

1. [x] in the above list refer to the camera address,

[y] = [x + 8]

## Pelco-D Protocol Command List

Function	Byte1	Byte2	Byte3	Byte4	Byte5	Byte6	Byte7
<b>Up</b>	0xFF	Address	0x00	0x08	Pan Speed	Tilt Speed	SUM
<b>Down</b>	0xFF	Address	0x00	0x10	Pan Speed	Tilt Speed	SUM
<b>Left</b>	0xFF	Address	0x00	0x04	Pan Speed	Tilt Speed	SUM
<b>Right</b>	0xFF	Address	0x00	0x02	Pan Speed	Tilt Speed	SUM
<b>Zoom In</b>	0xFF	Address	0x00	0x20	0x00	0x00	SUM
<b>Zoom Out</b>	0xFF	Address	0x00	0x40	0x00	0x00	SUM
<b>Focus Far</b>	0xFF	Address	0x00	0x80	0x00	0x00	SUM
<b>Focus Near</b>	0xFF	Address	0x01	0x00	0x00	0x00	SUM
<b>Set Preset</b>	0xFF	Address	0x00	0x03	0x00	Preset ID	SUM
<b>Clear Preset</b>	0xFF	Address	0x00	0x05	0x00	Preset ID	SUM
<b>Call Preset</b>	0xFF	Address	0x00	0x07	0x00	Preset ID	SUM
<b>Auto Focus</b>	0xFF	Address	0x00	0x2B	0x00	0x01	SUM
<b>Manual Focus</b>	0xFF	Address	0x00	0x2B	0x00	0x02	SUM
<b>Query Pan Position</b>	0xFF	Address	0x00	0x51	0x00	0x00	SUM
<b>Query Pan Position Response</b>	0xFF	Address	0x00	0x59	Value High Byte	Value Low Byte	SUM
<b>Query Tilt Position</b>	0xFF	Address	0x00	0x53	0x00	0x00	SUM
<b>Query Tilt Position Response</b>	0xFF	Address	0x00	0x5B	Value High Byte	Value Low Byte	SUM
<b>Query Zoom Position</b>	0xFF	Address	0x00	0x55	0x00	0x00	SUM
<b>Query Zoom Position Response</b>	0xFF	Address	0x00	0x5D	Value High Byte	Value Low Byte	SUM

## Pelco-P Protocol Command List

Function	Byte1	Byte2	Byte3	Byte4	Byte5	Byte6	Byte7	Byte8
<b>Up</b>	0xA0	Address	0x00	0x08	Pan Speed	Tilt Speed	0xAF	XOR
<b>Down</b>	0xA0	Address	0x00	0x10	Pan Speed	Tilt Speed	0xAF	XOR
<b>Left</b>	0xA0	Address	0x00	0x04	Pan Speed	Tilt Speed	0xAF	XOR
<b>Right</b>	0xA0	Address	0x00	0x02	Pan Speed	Tilt Speed	0xAF	XOR
<b>Zoom In</b>	0xA0	Address	0x00	0x20	0x00	0x00	0xAF	XOR
<b>Zoom Out</b>	0xA0	Address	0x00	0x40	0x00	0x00	0xAF	XOR
<b>Focus Far</b>	0xA0	Address	0x00	0x80	0x00	0x00	0xAF	XOR
<b>Focus Near</b>	0xA0	Address	0x01	0x00	0x00	0x00	0xAF	XOR
<b>Set Preset</b>	0xA0	Address	0x00	0x03	0x00	Preset ID	0xAF	XOR
<b>Clear Preset</b>	0xA0	Address	0x00	0x05	0x00	Preset ID	0xAF	XOR
<b>Call Preset</b>	0xA0	Address	0x00	0x07	0x00	Preset ID	0xAF	XOR
<b>Auto Focus</b>	0xA0	Address	0x00	0x2B	0x00	0x01	0xAF	XOR
<b>Manual Focus</b>	0xA0	Address	0x00	0x2B	0x00	0x02	0xAF	XOR
<b>Query Pan Position</b>	0xA0	Address	0x00	0x51	0x00	0x00	0xAF	XOR
<b>Query Pan Position Response</b>	0xA0	Address	0x00	0x59	Value High Byte	Value Low Byte	0xAF	XOR
<b>Query Tilt Position</b>	0xA0	Address	0x00	0x53	0x00	0x00	0xAF	XOR
<b>Query Tilt Position Response</b>	0xA0	Address	0x00	0x5B	Value High Byte	Value Low Byte	0xAF	XOR
<b>Query Zoom Position</b>	0xA0	Address	0x00	0x55	0x00	0x00	0xAF	XOR
<b>Query Zoom Position Response</b>	0xA0	Address	0x00	0x5D	Value High Byte	Value Low Byte	0xAF	XOR

## VISCA over IP commands

The Avonic CM60-IP camera is implemented with a TCP server. The TCP port number is 5678 by default and can be altered in the WebGUI. Once the connection between client and server is set up, the client will be able to send PTZ commands to the server. The server then parses and executes the PTZ command.

The Avonic IP Camera has also implemented a UDP server. The UDP port number is fixed on 1259. Once the connection between client and server is set up, the client will be able to send PTZ commands to the server. The server then parses and executes the PTZ command.

The VISCA over IP command list is based on the VISCA protocol. Not all VISCA commands are implemented.

The PTZ Command format is according to the definition of the VISCA protocol. The VISCA address of the camera is set to 1 by default and can be changed in the WebGUI. As all cameras are uniquely identified by their IP address, all VISCA addresses of the cameras that are controlled over IP do not necessarily have to be unique.

Default settings:

TCP port	5678
UDP port	1259
VISCA address	1

The commands are as follow:

### Camera return commands

x= Camera Address

y= Socket Number

z = Camera Address + 8

All parameter values are in HEX

Return/complete Command			
Command	Function	Command Packet	Comments
ACK/Completion Messages	ACK	90 4y FF (y: Socket No.)	Return when the command is accepted.
	Completion	90 5y FF (y: Socket No.)	Return when the command has been executed.

Error command			
Command	Function	Command Packet	Comments
Error Messages	Syntax Error	90 60 02 FF	Returned when the command format is different or when a command with illegal command parameters is accepted.
	Command Buffer Full	90 60 03 FF	Indicates that two sockets are already being used(executing two commands) and the command could not be accepted when received.
	Command Canceled	90 6y 04 FF (y: Socket No.)	Returned when a command which is being executed in a socket specified by the cancel command is canceled. The completion message for the command is not returned.
	No Socket	90 6y 05 FF (y: Socket No.)	Returned when no command is executed in a socket specified by the cancel command, or when an

		invalid socket number is specified.
Command Not Executable	90 6y 41 FF (y: Execution command Socket No. Inquiry command: 0)	Returned when a command cannot be executed due to current conditions. For example, when commands controlling the focus manually are received during auto focus.

### Camera control commands

x= Camera Address

y= Socket Number

z = Camera Address + 8

All parameter values are in HEX

Command	Function	Command Packet	Comments
AddressSet	Broadcast	88 30 01 FF	Address setting
CAM_Zoom	Stop	81 01 04 07 00 FF	
	Tele(Standard speed)	81 01 04 07 02 FF	
	Wide(Standard speed)	81 01 04 07 03 FF	
	Tele(Variable speed)	81 01 04 07 2p FF	p = 0(low speed) - F(high speed)
	Wide(Variable speed)	81 01 04 07 3p FF	
	Direct	81 01 04 47 0p 0q 0r 0s FF	pqrs(0-F): Zoom Position
CAM_Focus	Stop	81 01 04 08 00 FF	

	Far(Standard speed)	81 01 04 08 02 FF	
	Near(Standard speed)	81 01 04 08 03 FF	
	Far(Variable speed)	81 01 04 08 2p FF	p = 0(low) - F(high)
	Near(Variable speed)	81 01 04 08 3p FF	
	Direct Focus Position	81 01 04 48 0p 0q 0r 0s FF	min p = 0, q = 0, r = 0, s = 0 max p = 0, q = 6, r = E, s = A
	Auto Focus	81 01 04 38 02 FF	AF On/Off
	Manual Focus	81 01 04 38 03 FF	
	Auto/Manual	81 01 04 38 10 FF	
CAM_WB	Auto	81 01 04 35 00 FF	Normal Auto
	Indoor mode	81 01 04 35 01 FF	Indoor mode
	Outdoor mode	81 01 04 35 02 FF	Outdoor mode
	OnePush mode	81 01 04 35 03 FF	One Push WB mode
	Manual	81 01 04 35 05 FF	Manual Control mode
	OnePush trigger	81 01 04 10 05 FF	One Push WB Trigger
CAM_RGain	Reset	81 01 04 03 00 FF	Manual Control of R Gain
	Up	81 01 04 03 02 FF	
	Down	81 01 04 03 03 FF	
	Direct	81 01 04 43 00 00 0p 0q FF	pq: R Gain
CAM_Bgain	Reset	81 01 04 04 00 FF	Manual Control of B Gain
	Up	81 01 04 04 02 FF	
	Down	81 01 04 04 03 FF	
	Direct	81 01 04 44 00 00 0p 0q FF	pq: B Gain



CAM_AE	Full Auto	81 01 04 39 00 FF	Automatic Exposure mode
	Manual	81 01 04 39 03 FF	Manual Control mode
	Shutter priority	81 01 04 39 0A FF	Shutter Priority Automatic Exposure mode
	Iris priority	81 01 04 39 0B FF	Iris Priority Automatic Exposure mode
	Bright	81 01 04 39 0D FF	Bright Mode(Manual control)
CAM_Iris	Reset	81 01 04 0B 00 FF	Iris Setting (CAM_AE is set to Iris Priority)
	Up	81 01 04 0B 02 FF	
	Down	81 01 04 0B 03 FF	
	Direct Iris Position	81 01 04 4B 00 00 0p 0q FF	min p = 0 q = 0 max p = 0, q = C
CAM_Gain	Reset	81 01 04 0C 00 FF	Gain Setting
	Up	81 01 04 0C 02 FF	
	Down	81 01 04 0C 03 FF	
	Direct	81 01 04 0C 00 00 0p 0q FF	pq: Gain Position
	Gain Limit	81 01 04 2C 0p FF	p: Gain Position
CAM_Bright	Reset	81 01 04 0D 00 FF	Bright Setting
	Up	81 01 04 0D 02 FF	
	Down	81 01 04 0D 03 FF	
	Direct	81 01 04 0D 00 00 0p 0q FF	pq: Bright Position
CAM_ExpComp	On	81 01 04 3E 02 FF	Exposure Compensation On/Off
	Off	81 01 04 3E 03 FF	
	Reset	81 01 04 0E 00 FF	Exposure Compensation Amount Setting
	Up	81 01 04 0E 02 FF	
	Down	81 01 04 0E 03 FF	

	Direct	81 01 04 4E 00 00 0p 0q FF	pq: ExpComp Position
CAM_BackLight	On	81 01 04 33 02 FF	Back Light Compensation On/Off
	Off	81 01 04 33 03 FF	
CAM_NR(2D)Mode	Auto	81 01 04 50 02 FF	ND2D Auto/Manual
	Manual	81 01 04 50 03 FF	
CAM_NR(2D)Level	-	81 01 04 53 0p FF	p: NR Setting (0: Off, level 1 to 5)
CAM_NR(3D)Level	-	81 01 04 54 0p FF	p: NR Setting (0: Off, level 1 to 8)
CAM_Flicker	-	81 01 04 23 0p FF	p: Flicker Settings (0: Off, 1: 50Hz, 2: 60Hz)
CAM_DHotPixel	-	81 01 04 56 0p FF	p: Dynamic Hot Pixel Setting (0: Off, level 1 to 6)
CAM_ApertureMode(sharpness)	Auto	81 01 04 05 02 FF	Sharpness Auto
	Manual	81 01 04 05 02 FF	Sharpness Manual
CAM_Aperture(sharpness)	Reset	81 01 04 02 00 FF	Aperture Control
	Up	81 01 04 02 02 FF	
	Down	81 01 04 02 03 FF	
	Direct	81 01 04 42 00 00 0p 0q FF	
CAM_PictureEffect	Off	81 01 04 63 00 FF	Picture Effect Setting
	B&W	81 01 04 63 04 FF	
CAM_Memory	Reset	81 01 04 3F 00 pp FF	pp: Memory Number(=0 to 127)
	Set	81 01 04 3F 01 pp FF	
	Recall	81 01 04 3F 02 pp FF	
CAM_LR_Reverse	On	81 01 04 61 02 FF	Image Flip Horizontal On/Off
	Off	81 01 04 61 03 FF	

CAM_PictureFlip	On	81 01 04 66 02 FF	Image Flip Vertical On/Off
	Off	81 01 04 66 03 FF	
CAM_ColorGain	Diret	81 01 04 49 00 00 00 0p FF	p: Color Gain setting 0h (60%) to Eh (200%)
SYS_Menu	Off	81 01 06 06 03 FF	Turns on/off the menu screen
	On	81 01 06 06 02 FF	
Pan_tiltDrive	Up	81 01 06 01 VV WW 03 01 FF	VV: Pan speed 0x01 (low speed) to 0x18 (high speed) WW: Tilt speed 0x01 (low speed) to 0x14 (high speed) YYYY: Pan Position ZZZZ: Tilt Position
	Down	81 01 06 01 VV WW 03 02 FF	
	Left	81 01 06 01 VV WW 01 03 FF	
	Right	81 01 06 01 VV WW 02 03 FF	
	Upleft	81 01 06 01 VV WW 01 01 FF	
	Upright	81 01 06 01 VV WW 02 01 FF	
	DownLeft	81 01 06 01 VV WW 01 02 FF	
	DownRight	81 01 06 01 VV WW 02 02 FF	
	Stop	81 01 06 01 VV WW 03 03 FF	
	AbsolutePosition	81 01 06 02 VV WW 0Y 0Y 0Y 0Y 0Z 0Z 0Z 0Z FF	
	RelativePosition	81 01 06 03 VV WW 0Y 0Y 0Y 0Y 0Z 0Z 0Z 0Z FF	
	Home	81 01 06 04 FF	
	Reset	81 01 06 05 FF	

Pan_tiltLimitSet	LimitSet	81 01 06 07 00 0W 0Y 0Y 0Y 0Y 0Z 0Z 0Z 0Z FF	W: 1 UpRight 0: DownLeft YYYY: Pan Limit Position ZZZZ: Tilt Position
	LimitClear	81 01 06 07 01 0W 07 0F 0F 0F 07 0F 0F 0F FF	
CAM_AFSensitivity	High	81 01 04 58 01 FF	AF Sensitivity High/Normal/Low
	Normal	81 01 04 58 02 FF	
	Low	81 01 04 58 03 FF	
CAM_SettingReset	Reset	81 01 04 A0 10 FF	Reset Factory Setting
CAM_Brightness	Direct	81 01 04 A1 00 00 0p 0q FF	pq: Brightness Position
CAM_Contrast	Direct	81 01 04 A2 00 00 0p 0q FF	pq: Contrast Position
CAM_Flip	Off	81 01 04 A4 00 FF	Single Command For Video Flip
	Flip-H	81 01 04 A4 01 FF	
	Flip-V	81 01 04 A4 02 FF	
	Flip-HV	81 01 04 A4 03 FF	
CAM_SettingSave	Save	81 01 04 A5 10 FF	Save Current Setting
CAM_Iridix	Direct	81 01 04 A7 00 00 0p 0q FF	pq: Iridix Position
CAM_AWBSensitivity	High	81 01 04 A9 00 FF	High
	Normal	81 01 04 A9 01 FF	Normal
	Low	81 01 04 A9 02 FF	Low
CAM_AFZone	Top	81 01 04 AA 00 FF	AF Zone weight select
	Center	81 01 04 AA 01 FF	
	Bottom	81 01 04 AA 02 FF	
CAM_ColorHue	Direct	81 01 04 4F 00 00 00 0p FF	p: Color Hue setting 0h (- 14 degrees) to Eh (+14 degrees)

## Inquiry Commands

x= Camera Address

y= Socket Number

z = Camera Address + 8

All parameter values are in HEX

Inquiry Command			
Command	Command Packet	Packet	Comments
CAM_ZoomPosIn q	81 09 04 47 FF	90 50 0p 0q 0r 0s FF	pqrs: Zoom Position
CAM_FocusAFMo delInq	81 09 04 38 FF	90 50 02 FF	Auto Focus
		90 50 03 FF	Manual Focus
CAM_FocusPosIn q	81 09 04 48 FF	90 50 0p 0q 0r 0s FF	pqrs: Focus Position
CAM_WBModeln q	81 09 04 35 FF	90 50 00 FF	Auto
		90 50 01 FF	Indoor mode
		90 50 02 FF	Outdoor mode
		90 50 03 FF	OnePush mode
		90 50 05 FF	Manual
CAM_RGainInq	81 09 04 43 FF	90 50 00 00 0p 0q FF	pq: R Gain
CAM_BGainInq	81 09 04 44 FF	90 50 00 00 0p 0q FF	pq: B Gain
CAM_AEModelnq	81 09 04 39 FF	90 50 00 FF	Full Auto
		90 50 03 FF	Manual
		90 50 0A FF	Shutter priority
		90 50 0B FF	Iris priority
		90 50 0D FF	Bright

CAM_ShutterPosInq	81 09 04 4A FF	90 50 00 00 0p 0q FF	pq: Shutter Position
CAM_IrisPosInq	81 09 04 4B FF	90 50 00 00 0p 0q FF	pq: Iris Position
CAM_BrightPosInq	81 09 04 4D FF	90 50 00 00 0p 0q FF	pq: Bright Position
CAM_ExpCompModelInq	81 09 04 3E FF	90 50 02 FF	On
		90 50 03 FF	Off
CAM_ExpCompPositionInq	81 09 04 4E FF	90 50 00 00 0p 0q FF	pq: ExpComp Position
CAM_BacklightModelInq	81 09 04 33 FF	90 50 02 FF	On
		90 50 03 FF	Off
CAM_Noise2DModelInq	81 09 04 50 FF	90 50 02 FF	Auto Noise 2D
		90 50 03 FF	Manual Noise 3D
CAM_Noise2DLevel	81 09 04 53 FF	90 50 0p FF	Noise Reduction (2D) p: 0 to 5
CAM_Noise3DLevel	81 09 04 54 FF	90 50 0p FF	Noise Reduction (3D) p: 0 to 8
CAM_FlickerModelInq	81 09 04 55 FF	90 50 0p FF	p: Flicker Settings(0: OFF, 1: 50Hz, 2: 60Hz)
CAM_ApertureModelInq(Sharpness)	81 09 04 05 FF	90 50 02 FF	Auto Sharpness
		90 50 03 FF	Manual Sharpness
CAM_ApertureInq(Sharpness)	81 09 04 42 FF	90 50 00 00 0p 0q FF	pq: Aperture Gain
CAM_PictureEffectModelInq	81 09 04 63 FF	90 50 02 FF	Off
		90 50 04 FF	B&W
CAM_MemoryInq	81 09 04 3F FF	90 50 0p FF	p: Memory number last operated.
SYS_MenuModelInq	81 09 06 06 FF	90 50 02 FF	On
		90 50 03 FF	Off

CAM_LR_Reverselnq	81 09 04 61 FF	90 50 02 FF	On
		90 50 03 FF	Off
CAM_PictureFliplnq	81 09 04 66 FF	90 50 02 FF	On
		90 50 03 FF	Off
CAM_ColorGainInq	81 09 04 49 FF	90 50 00 00 00 0p FF	p: Color Gain setting 0h (60%) to Eh (200%)
VideoSystemInq	81 09 06 23 FF	90 50 00 FF	1920x1080i60
		90 50 01 FF	1920x1080p30
		90 50 02 FF	1280x720p60
		90 50 04 FF	NTSC
		90 50 05 FF	NTSC
		90 50 06 FF	NTSC
		90 50 07 FF	1920x1080p60
		90 50 08 FF	1920x1080i50
		90 50 09 FF	1920x1080p25
		90 50 0A FF	1280x720p50
		90 50 0C FF	PAL
		90 50 0D FF	PAL
		90 50 0E FF	PAL
Pan-tiltMaxSpeedInq	81 09 06 11 FF	90 50 ww zz FF	ww: Pan Max Speed zz: Tilt Max Speed
Pan-tiltPosInq	81 09 06 12 FF	90 50 0w 0w 0w 0w 0z 0z 0z 0z FF	www: Pan Position zzz: Tilt Position
CAM_GainLimitInq	81 09 04 2C FF	90 50 0q FF	p: Gain Limit
CAM_DHotPixelInq	81 09 04 56 FF	90 50 0q FF	p: Dynamic Hot Pixel Setting (0: Off, level 1 to 6)
	81 09 04 58 FF	90 50 01 FF	High

CAM_AFSensitivityInq		90 50 02 FF	Normal
		90 50 03 FF	Low
CAM_BrightnessInq	81 09 04 A1 FF	90 50 00 00 0p 0q FF	pq: Brightness Position
CAM_ContrastInq	81 09 04 A2 FF	90 50 00 00 0p 0q FF	pq: Contrast Position
CAM_FlipInq	81 09 04 A4 FF	90 50 00 FF	Off
		90 50 01 FF	Flip-H
		90 50 02 FF	Flip-V
		90 50 03 FF	Flip-HV
CAM_IridixInq	81 09 04 A7 FF	90 50 00 00 0p 0q FF	pq: Iridix Position
CAM_AFZone	81 09 04 AA FF	90 50 00 FF	Top
		90 50 01 FF	Center
		90 50 02 FF	Bottom
CAM_ColorHueInq	81 09 04 4F FF	90 50 00 00 00 0p FF	p: Color Hue setting 0h (- 14 degrees) to Eh (+14 degrees)
CAM_AWBSensitivityInq	81 09 04 A9 FF	90 50 00 FF	High
		90 50 01 FF	Normal
		90 50 02 FF	Low



# Appendix B Dimensions

Front

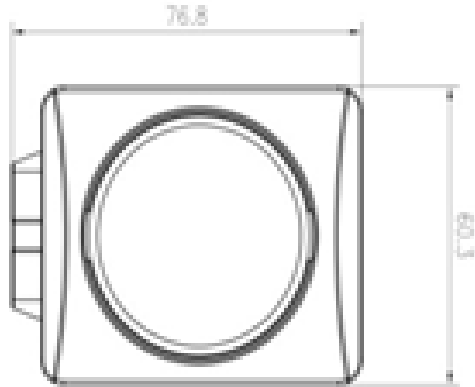

Rear

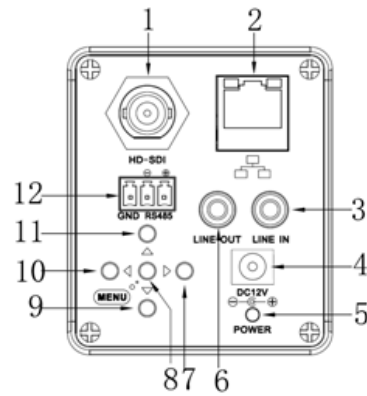

Top

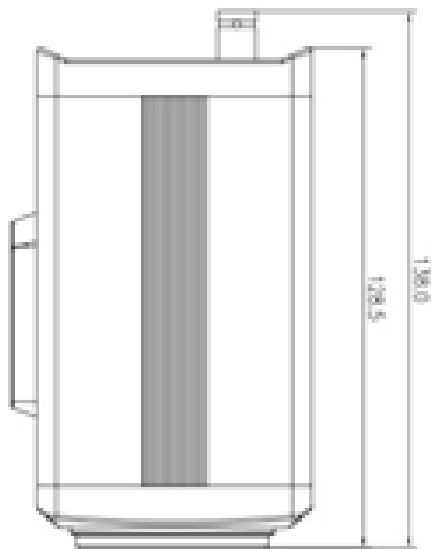

Side

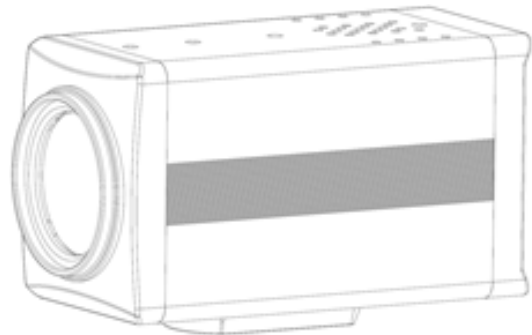

Bottom

All sizes are in mm

Weight: 0.85 kg