

Introduction

Welcome to the Harrison family of 500 series modules and thank you for your purchase of the Comp (compressor) module. All Harrison 500 series modules are compatible with the API 500 format rack systems.

The Comp will be a tremendous asset to your studio workflow and recording process.

The Comp includes a classic circuit design that provides warm yet extremely accurate results. This compressor design uses state of the art component technologies while preserving the sound quality found on 100's of hit records produced over the decades.

With your new Comp module your recordings will instantly add that punch and smoothness that only comes with high performance analog circuit design along with decades of experience in professional audio product design and development.

The Comp will allow you to artistically manipulate the dynamic content of a signal. This type of control can make a vocal sound more consistent, or increase the 'room' sound of a drum mix, or accentuate the attack of a snare drum.

This module has been specifically designed to operate in a 500 format rack such as the API lunch box or equivalent. In common with many such modules, the nominal input / output operating level is +4 dBu.

Thank you!
The Harrison Team

Comp Controls

Makeup Knob: this knob increases the output level, post-compressor. Since a compressor normally reduces the volume of a signal, it is desirable to raise the overall level, post-compression. This extra gain is disabled when you disable the compressor, which allows you to compare the compressed and uncompressed (dry) signal at a comparable volume.

Gain Reduction Meter: this meter indicates the amount of gain-reduction being applied indicated by 2dB of gain reduction per LED.

Release Knob: this knob adjusts the speed at which the compressor will return to unity gain, if compression was occurring and now the input signal sinks below the threshold.

Ratio Knob: increase this knob to increase the effect of the Compressor processing.

Threshold Knob: turn the threshold knob down to meet the average signal level.

IN Switch: use the IN switch to toggle the compressor in and out of circuit for a/b comparison.



- 4 -

- 5 -

Block Diagram

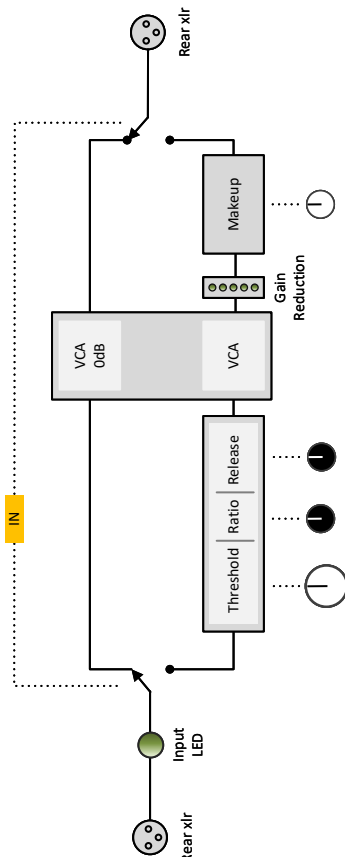

- 6 -

Use

Try your new Comp compressor module on any kind of input source. Use it on vocals, drums, acoustic or electric guitars, keyboards etc. etc. Discover what a well-crafted no nonsense compressor design can add to your arsenal the same way 100's of legendary engineers did using Harrison consoles through the decades.

Set the Comp ratio very low and the release very fast and use the Comp as a 'leveler' to transparently reduce the level of the loudest parts so the track has a more consistent level, or to allow the initial sound to be passed through at full volume while reducing the 'body' of the sound slightly.

By providing full control of Threshold, Release, Ratio and the Makeup output level the Comp is the perfect 'no nonsense' compression tool to bring loud signals down while allowing the quieter signals to sound just as loud giving that 'nearby' or 'in-your-face' effect.

Enjoy!

- 7 -